

# QUALITROL® 149-400

SF<sub>6</sub> gas density monitors with remote output



## Accurate SF<sub>6</sub> gas density monitor providing exceptional reliability

- Simplify your emissions reporting and avoid costly SF<sub>6</sub> fines with accurate gas measurement
- Avoid unexpected asset failure through a predictive maintenance approach; pair visual indication and 4-20 mA analog signal to indicate low gas density levels
- Rugged gauge design and corrosion resistant materials ensure product life

### Product Summary

**Description** Provides local mechanical indication of levels of SF<sub>6</sub> gas as well as 4-20 mA analog remote output. Unit automatically compensates for gas pressure changes due to ambient temperature. Offers alarm and limit control with up to three factory set relays.

**Application** For use on high and medium voltage gas insulated circuit breakers (live and dead tank), switchgear bushings and transformers. For gas density monitoring applications that require local and remote indication and optimal relays for alarm and limit control.



**QUALITROL®**  
Defining Reliability

## QUALITROL 149-400 SF<sub>6</sub> gas density monitors with remote output

**Accurate SF<sub>6</sub> gas density monitor providing exceptional reliability**

- Large dial face with many standard and custom displays for clear visual indication of the SF<sub>6</sub> gas density
- Temperature compensated indication provides most accurate monitoring of gas levels within the tank
- Measurement accuracy of  $\pm 2\%$  of full scale

**Avoid unexpected asset failure through a predictive maintenance approach; pair visual indication and 4-20 mA analog signal to indicate low gas density levels**

- Visual indication of SF<sub>6</sub> levels may be seen on the manual dial face of the instrument
- 4-20 mA analog output for integration into a SCADA system
- 3 Form A relays may be triggered when the density level drops below a pre-defined value

**Rugged gauge design and corrosion resistant materials ensure product life**

- Stainless steel and brass external parts offer protection against harsh environmental conditions
- Standard 5 year warranty
- Vented case with UV stabilized polycarbonate lens is moisture intrusion resistant

### SF<sub>6</sub> gas density monitor device features

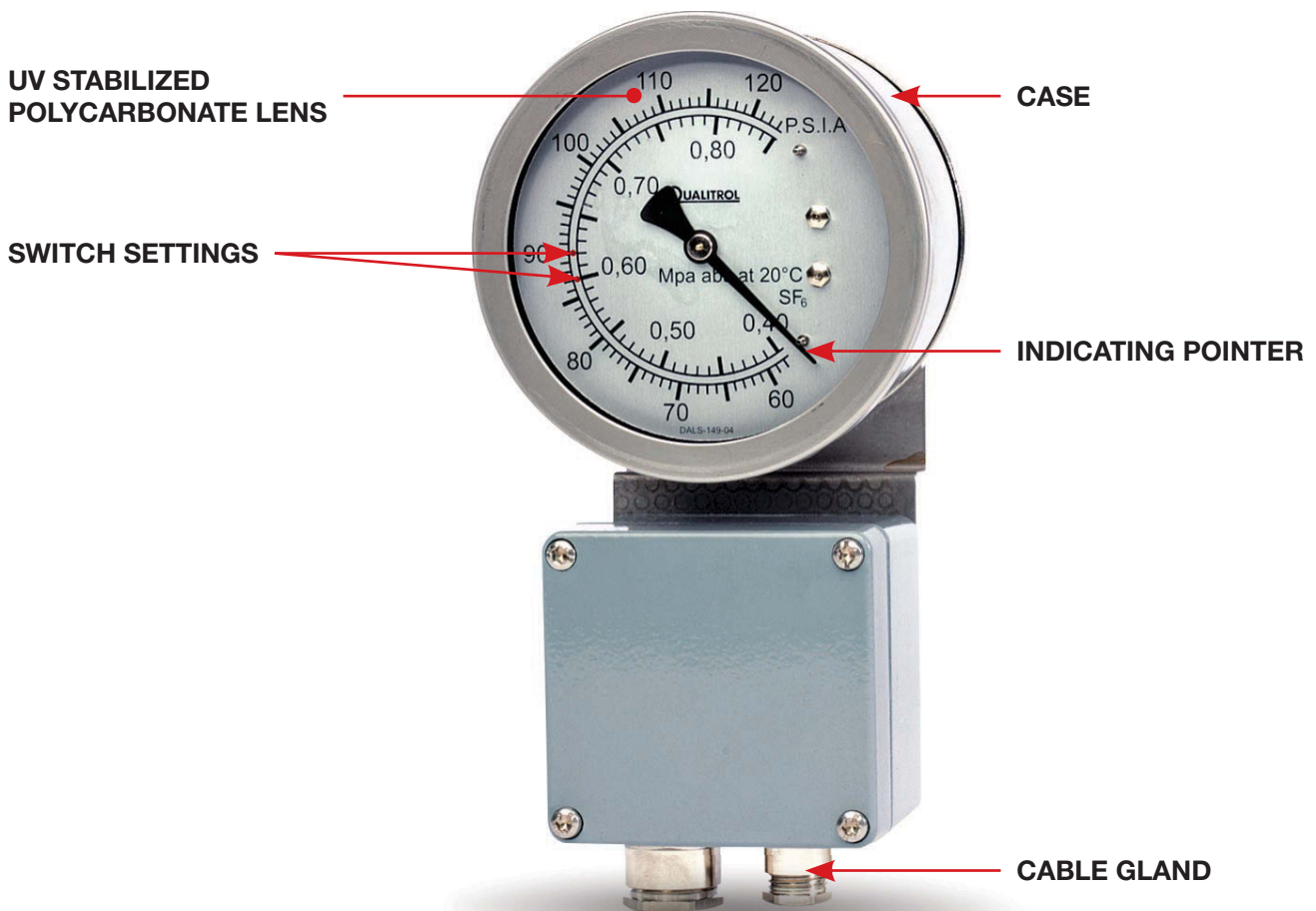



## TECHNICAL SPECIFICATIONS

<b>Power supply</b>	Voltage	24 VDC, $\pm 2$ VDC
<b>Accuracy</b>	Indication	2% of max scale value within the full temperature range at fill pressure (dial reading) and $\pm 1\%$ of max scale value at any pressure within scaled range (remote output)
	Alarm	1% of max scale value for the temperature range at any pressure within scaled range
<b>Remote output</b>		4-20 mA DC (max. resistive load 500 $\Omega$ )
<b>Relays</b>	Alarms	3 independent SPDT relays with user configurable setpoints, hysteresis, failsafe / non-failsafe operation, time delays
	Contact ratings	30 VDC, 2A, 60 W, NO only 110 VDC, 0.3 A, 33 W 220 VDC, 0.27 A, 60 W 125 VAC, 0.5 A, 62.5 W 250 VAC, 0.25 A, 62.5 W
<b>Dielectric isolation</b>	High-Pot	1500 VAC, 60 seconds to ground
<b>Configuration</b>	Local	USB type B connector Qualitrol ITM Manager software
<b>Emissions</b>	Conducted / radiated	EN 55022 / FCC Part 15
<b>Immunity</b>	Conducted / radiated	EN 61000-4-2, EN 61000-4-3, EN 61000-4-4, EN 61000-4-5, EN 61000-4-6, EN 61000-4-8
<b>Mounting</b>	Standard	Shock mounts
<b>Temperature</b>	Operating	-40 to +70° C
	Storage	-50 to +80° C
<b>Humidity</b>		90% non-condensing
<b>Vibration</b>		50/60 Hz @ .004 inch displacement
<b>Shock</b>		10 Gs half-sine, in 3 orthogonal planes
<b>Enclosure</b>	Protection	IP65



### Don't see what you need?

Qualitrol regularly creates models with special customer requirements. Contact your local sales representative or Qualitrol Applications Engineer to review your special requirements.



## Dimensions

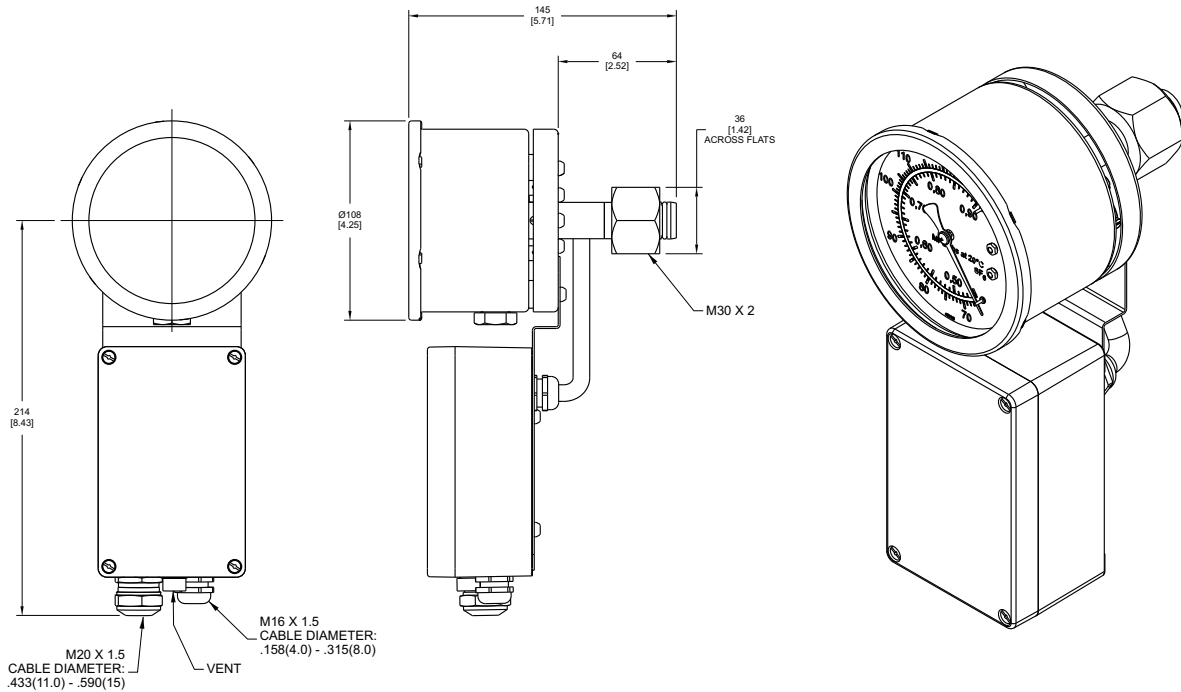

## Wire schematic

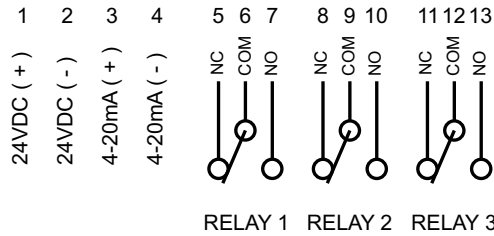

### QUALITROL® Field Services

QUALITROL® provides on-site commissioning/start-up and comprehensive maintenance contracts to all customers worldwide. To further improve reliability, an extended warranty is available on selected products commissioned by QUALITROL®.

### QUALITROL® Educational Services

QUALITROL® professional training (designed to achieve hands-on performance based objectives) prepares operations, maintenance, and engineering personnel to install, test, configure, operate and maintain QUALITROL® products.

### QUALITROL® Accelerated Delivery

QUALITROL® provides accelerated delivery on many products and services including replacements, spare parts and repairs.

### About QUALITROL®

Established in 1945, with continual improvement at the core of our business, QUALITROL® provides smart utility asset condition monitoring across the globe. We are the largest and most trusted global leader for partial discharge monitoring, asset protection equipment and information products across generation, transmission and distribution. At QUALITROL® we are redefining condition monitoring technology for Electric utilities assets.

©2014 QUALITROL® Company LLC, an ISO 9001 system certified company. QUALITROL is a registered trademark and OTIWTI is a trademark of QUALITROL® Company LLC. All trademarks are properties of their respective companies, as noted herein. All rights reserved. Information subject to change without notice. AP-B14-06L-01E.